

AUTOCLEAR® Backscatter Multi-Energy BZ-8880M

Cross-Enhanced Z®, Multi-Energy & Backscatter, Dual-View, Ultra-low-dose X-ray for Smuggled Explosives, IED's, Drugs & Threats (88 W x 82 H cm tunnel or 35" x 32.5" x Unlimited L)

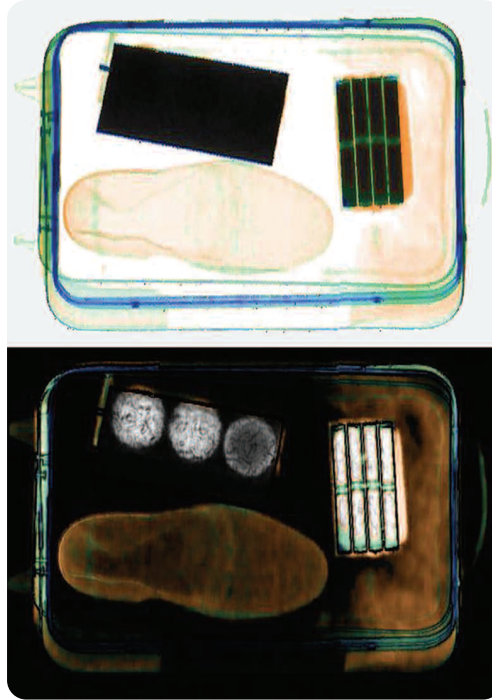

Multi-Energy, Dual-Mode Transmission View

Cross-Enhanced Z®, high resolution Multi-Energy, easy reference top view, with organic & metallic stripping, RealClear, autoOutline®, autoMatalert® & autoDensalert®.

Sharper, Cross-Enhanced Z®, Penetrating, Color Backscatter View

Brightly exposes & outlines hidden sheet explosive threat cleverly hidden behind segmented laptop batteries (on right) & rounded HME's & detonator masked as tennis balls.

Since its founding in 1937, AUTOCLEAR® has focused on the design, development, production & support of safer, user-friendly, non-invasive, highly effective security screening systems. Our security systems employ innovative technologies that provide rapid, automated detection of weapons, drugs and explosives, including Vehicle-Born and roadside IEDs. AUTOCLEAR®'s advanced security solutions deliver high performance detection capabilities with unparalleled operational efficiency for Government, VIP & Diplomatic, Mail, Law Enforcement & Military. AUTOCLEAR®'s portfolio includes Multi-Energy Backscatter scanners, Dual and Single View X-ray Scanners, Weapons and Whole Body Portals & Desktop & Handheld dual-mode Explosives & Narcotics Trace Detectors. AUTOCLEAR® has deployed more than 50,000 security screening systems worldwide.

The BZ-8880M is the industry leading scanner combining proprietary Enhanced Multi-Energy with Cross-Enhanced Z® Backscatter & Dual-Mode Photon Detection™. The BZ Series was developed from AUTOCLEAR®'s 13 years of experience with Compton Backscatter technology resulting in systems that produce both high resolution & greater penetration Multi-Energy & Backscatter imaging. This enables the BZ-8880M to rapidly & accurately reveal military, sheet, bulk, homemade & liquid explosives & IEDs. This technology equally detects ceramic and composite weapons, narcotics, banned produce, diamonds, currency, duty fraud, & ultra-thin or mixed threats. The BZ-8880M is engineered to reveal artfully concealed shaped or organic composite threats clearly in bright white & enhanced color. The BZ-8880M is easily transportable & suited for:

Customs/Border Interdiction • Embassies
High Threat Facilities • Military Facilities
Security Checkpoints • Nuclear Plants
Utilities & Petrochemical Plants • Prisons
Law Enforcement • High-Security Events
Ports • Airports • Naval/Coast Guard
Mail, Postal • Government Buildings • VIP

Features & Benefits

- ✓ Cross-Enhanced Z® Transmission Multi-Energy reference view is sharp & fully featured, with Dual-Mode Photon Detection™, organic & metallic stripping, RealClear, effective atomic number, analysis, Threat Image Projection (TIP), autoOutline®, autoMatalert® & autoDensalert®.
- ✓ Cross-Enhanced Z® Backscatter view with autoCatch®, autoOutline® & autoMatEnhance® is far sharper & 25% more penetrating than alternative approaches. Images faster & more reliably, stripping away extra parcel "clutter" & blockants. Sharply highlights hidden contraband in bright white and enhanced color.
- ✓ The single computer, generator, HV-power supply & monitor provide a highly reliable design, compared with other Dual-View systems, with lower MTBR & operating, maintenance & lifetime costs of ownership.
- ✓ Features a 27", 1920 x 1080 resolution flat panel LCD monitor, variable Smart Zoom® up to 64X, Light Enhance, Help Screens, Integrated Training Module, & Top/Bottom Windowing for fast & easy target identification with reduced operator fatigue.
- ✓ AUTOCLEAR®'s Backscatter technology employs less than 3% of the radiation emissions of other "film-safe" systems, reducing radiation exposure to operators.
- ✓ Greener energy use, using only a basic 10 or 15 amp circuit. autoSensing® safely replaces

troublesome photo-eye mechanisms & footpads. This unique design also ensures no missed screening of a weapon or explosive hidden in thin articles like magazines or courier envelopes, or of a parcel already in tunnel upon startup.

- ✓ The BZ-8880M's much larger tunnel size & shorter footprint assures higher throughput & application flexibility with its fold-up entry & exit tables. The rugged autoTracking® conveyor system never needs adjustment, reducing operating costs & downtime. The system is easily transportable: even through a 31" (77 cm) wide door or elevator.
- ✓ Critical sub-assemblies engineered & produced by AUTOCLEAR® in North America. No fluids to check, or troubling PCB batteries to replace.

Key Benefits

- Removes clutter & blockants more rapidly & effectively
- Reduces lifetime costs, MTBR & maintenance due to:
 1. No "twin" generators, computers, power supplies
 2. Exclusive autoTracking® & autoSensing® features
- Ultra-low-dose (over 30x less), for by far the highest level of safety, also saving energy
- Cross-Enhanced Z® in Multi-Energy/Dual Mode & Backscatter: deeper, sharper, color views
- Better throughput & transportability
- Easier to operate & reference with top & bottom automated views for faster target ID

The Ultimate in Concealed Contraband Detection

AUTOCLEAR®
autoclearus.com

Scintrex® • CheckGate® • Control Screening® • Dynavision® • Federal Labs®
U.S. Canada Europe UAE Beijing Hong Kong Singapore Latin America

BZ-8880M Cross Enhanced Z®, Multi-Energy & Backscatter, Ultra-low-dose 88 x 82 X-ray

Inspection Capabilities

Tunnel Size:	35.0" W (88.9 cm) x 32.5" H (82.1 cm) x unlimited length
Transmission Penetration:	30 mm (1.18") steel.
Backscatter Penetration:	25% more penetration than outdated "phosphor-detector" Backscatter.
Contrast Sensitivity:	Over 16 million grey & color levels
Resolution:	38-40 AWG typical*.
Processing:	32-bit adaptive image processing with minimum 128 Mbytes memory; 2.4 GHz or higher processor.
Mobility:	Large handles and flat-proof swivel, non-marring wheels allow easy relocation through narrow standard doors & elevators, (77cm or 31" wide). Less weight to push.
Conveyor:	Continuous operation. Automatically screens parcels in tunnel on start-up.
Pulling Weight:	160 kg (352 lbs) capacity. Stronger pulling weights available.
autoTracking®:	Belt warrantied to autoTrack for life. Continuous operation (forward or reverse).
Initial System Warm-up:	3 minutes (typical). 3-12 minutes during rare generator protective reseasoning.

X-ray Generator

X-ray tube head:	Self-contained and self-rectified. Automatic seasoning & hour timer.
High voltage operating:	Minimum 160 kV rated, 160 kV operating, high frequency. Far lighter and easier to maintain.
Duty cycle:	100% sealed oil bath cooling. (No fluids to top off). No redundant generator, HV power supply, computer or monitor: far less downtime & lower lifetime costs.
Beam orientation, Coverage:	Vertically upward. Full parcel coverage, both images. No corner cut-off on either view.

Health & Safety

Dose rate per exam, or periodically around parcel, under curtains:	< 10 µR; proprietary non-fanbeam design ensures ultra-low dose: <i>less than 3%</i> of the effective dose of other, merely "film-safe" Backscatter. .02 mR (.2 µSv) per exposure. ANSI compliant.
Compliance:	Fully exceeds all applicable federal health & safety regulations, including but not limited to 21 CFR J1020.40; 14 CFR 108.17 and 129.26.
Operator Safety:	Operator receives less than 1.0 µSv (0.1 mR/hr) at 2" (5 cm) from cabinet. Shielded x-ray curtain(s). autoSensing® safe, automatic operator shut-off.

X-ray Detectors

Optimized detection geometry with advanced, proprietary electron multiplication & dual mode pulse processing. Faster, more efficient, higher quality "light-piped," patented detection. Displays simultaneous, corresponding Multi-Energy Transmission & Backscatter Views of military, homemade or liquid explosives, IED's, drugs, ceramic or composite weapons, currency, diamonds, thin items & other organic or mixed threats hidden within dense or confused parcel contents.

Image Display

Dual detector & auto & edge-enhanced (see above), direct Transmission & Backscatter color X-ray Windowed Views. Color 27" or larger high resolution LCD flat screen views, 1920 x 1080 pixels.

Standard Features

- Cross-Enhanced Z® Backscatter & Multi-Energy Dual Mode Color Views with organic & metallic stripping
- 100 images Save & Restore on hard drive
- RealClear, autoTracking® & autoSensing®
- autoDensAlert® (variable, for batteries & metallic threats)
- autoCatch® Backscatter feature strips blockants
- autoOutline® reveals hidden threats in Multi-Energy image
- Dark & light enhance; Low Density & Stripping
- Network & Linux capable
- autoMatAlert® Cross-Enhanced Z®: circles organic threats
- 2, 3, 4, 6, 8, 16, 32 & 64X rapid, dual-view, continuous Smart Zoom (with 1.5, 2.5, 3.5 variable zoom).
- Low Density & Stripping
- High Density (virtually higher penetration); DensityScan
- Hour meter with automatic generator seasoning
- Adjustable-height, ergonomic, friendly, robust keyboard
- Brushed alum. tunnel extensions
- Help Screens, Integrated Training Module & Diagnostics
- Reverse view, enhanced
- Comprehensive, fully featured color manual
- Built-in folding conveyor extension & table

Optional Features

- autoMatEnhance®: automatic Cross-Enhanced Z® tools & features for ultimate contraband detection, user adjustable.
- 10,000 image autoArchiving® with autoSave® to DVD, CD or USB Flash
- Finer wire gauge optimized detection
- Different size flat LCD display
- CE marking, UL or other registrations
- kV, mA meter, or item counter
- Threat Image Projection (TIP)
- Tamperproof monitor/keypad garage
- Remote printer, networking, console or display
- Rental or lease
- autoNet - live networking
- Loading/exit rollerbeds (2, 3, 6ft; 1, 1.5, 2m)
- Global Power Conditioner or UPS
- Expanded variable density control
- Computer Based Trainer
- Differing pulling motors
- Linux rapid operating system

Physical Details

Dimensions:	155.9 cm (61.4") L x 166.7 cm (65.6") W x 175 cm (69") H [when unfolded for use] 195.6 cm (77.0") L x 76.9 cm (30.1") W x 182.6 cm (71.9") H [when folded-up for relocation]
Weight:	1,830 lbs (830 kg) uncrated. 2,130 lbs (966 kg) crated.
Construction:	Heavy gauge painted steel, patented, proven unibody construction with brushed stainless & aluminum trim & accessories. See "Mobility" spec. above. Corrosion-free, adjustable height, fully featured operator console.
Temperature:	Operating: 3° - 40°C (37° - 104°F) Storage: -48°C to 60°C (-40° - 140°F) Humidity: No visible moisture
Power:	Consumption: <1.7 kVA, single phase 15A standard outlet, 120 VAC ± 10% (<15amps, single phase) 200, 220, 230, 240, 250 VAC ± 10% (<7 amps). 50/60 Hz.

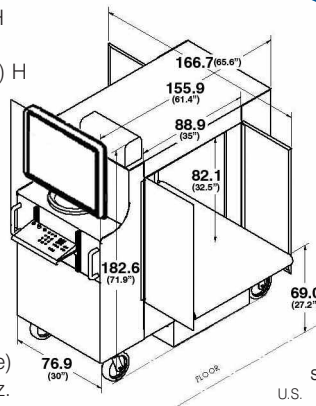

www.autoclearus.com

World Headquarters & Labs North & Latin American Sales

2 Gardner Road
Fairfield, NJ 07004-2206 USA
info@autoclearus.com
Tel: + 1 (973) 276-6161
Fax: + 1 (973) 276-6162
Toll Free: 1-800-231-6414 (US/Can)

U.S. Military

DOD@autoclearus.com
Tel: + 1 (443) 732-0766

Europe & North Africa

eu@autoclearus.com
Tel: + 33 2 38 61 97 00
Fax: + 33 2 38 61 97 01
seu@autoclearus.com Southern EU
Tel/Fax: + 34 91 650 89 86

Asia-Pacific

sasia@autoclearus.com SE Asia
nasia@autoclearus.com N Asia & Austr.
china@autoclearus.com Mainland

Middle East

Dubai, UAE
ME@autoclearus.com
Tel: + 971 6 557 4505
Fax: + 971 6 557 4507

Canada & Scintrex Trace

info@scintrextrace.com
300 Parkdale Ave., Ottawa
Ontario, Canada K1Y 1G2
Tel: + 1 (613) 224-1061
Fax: + 1 (613) 224-2603



ISO 9001-2000 Certified

U.S. Patents 7,072,440
6,661,867
6,304,629

www.autoclearus.com
www.tracedetection.com

The Ultimate in Concealed Contraband Detection

AUTOCLEAR®

Scintrex® • CheckGate® • Control Screening® • Dynavision® • Federal Labs®
U.S. Canada Europe UAE Beijing Hong Kong Singapore Latin America